

Fast Reeve Crane Blocks 6 sheave

Product information



General:

- Standard Reeve Crane Blocks may be used on a wide variety of land based cranes such as mobile and crawler cranes. They are an excellent choice where frequent block change is required.
- Double sealed maintenance free roller bearings.
- Design Factor of Safety of 4:1.
- Forged high tensile steel DIN hooks.
- Ductile iron sheaves, featuring graphite lubricated groove.
- High impact resistant side plates.
- Operational temperature range -40 up to +80°C.
- Lubrication on hook suspension.
- 4 or 8 point hook locking device.
- Fast reeve guide for fast reeving.
- Safety latch with locking pin.
- C3M finish in signal yellow with black striping.

Options:

- Double hook.
- Double hook with shackle hole.
- Quad hook.
- Shackle stud eye.

Important:

Inquiries for custom versions are welcome!

[... Read more](#)

Safety factor: 4:1

Fast Reeve Crane Blocks 6 sheave

Blueprint

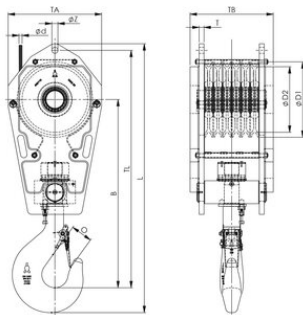

Technical data

Код товара	WLL ton	Model	Rope Ø mm	Sheave dia. mm	Hooksize	B mm	L mm	O mm	T mm	TA mm	TB mm	TLmm mm	Ø D1 mm	Ø D2 mm	Ø Z mm	Bec kg
6097FRB36019663EA	63	FRB 360 .19 .6 .63 .E .A	19	420 / 360	16	973	-	97	30	510	522	1 243	420	360	37	680
6097FRB36019663EB	63	FRB 360 .19 .6 .63 .E .B	19	420 / 360	16	973	-	97	30	510	522	1 243	420	360	37	725
6097FRB40019663E	63	FRB 400 .19 .6 .63 .E	19	460 / 400	16	1 063	-	97	30	570	507	1 363	460	400	37	775
6097FRB40019680E	80	FRB 400 .19 .6 .80 .E	19	460 / 400	20	1 147	1 597	110	30	570	507	1 447	460	400	43	820
6097FRB40022680E	80	FRB 400 .22 .6 .80 .E	22	460 / 400	20	1 147	1 597	110	40	570	507	1 447	460	400	43	820
6097FRB45022680E	80	FRB 450 .22 .6 .80 .E	22	515 / 450	20	1 187	1 730	110	40	600	502	1 580	515	450	43	910
6097FRB45024680E	80	FRB 450 .24 .6 .80 .E	24	515 / 450	20	1 187	1 730	110	45	600	502	1 580	515	450	52	910
6097FRB450246100E	100	FRB 450 .24 .6 .100 .E	24	515 / 450	25	1 263	1 768	132	45	600	582	1 598	515	450	52	1 135
6097FRB450266100E	100	FRB 450 .26 .6 .100 .E	26	515 / 450	25	1 263	1 768	132	45	600	582	1 598	515	450	52	1 135
6097FRB528246150E	150	FRB 528 .24 .6 .150 .E	24	596 / 528	40	1 553	2 232	167	45	710	642	2 020	596	528	52	1 800
6097FRB528266150E	150	FRB 528 .26 .6 .150 .E	26	596 / 528	40	1 553	2 232	167	45	710	642	2 020	596	528	52	1 800
6097FRB528286150E	150	FRB 528 .28 .6 .150 .E	28	596 / 528	40	1 553	2 242	167	50	710	642	2 030	596	528	59	1 800
6097FRB528266160E	160	FRB 528 .26 .6 .160 .E	26	596 / 528	40	1 581	2 178	167	45	710	682	1 966	596	528	52	2 270
6097FRB528286160E	160	FRB 528 .28 .6 .160 .E	28	596 / 528	40	1 581	2 188	167	50	710	682	1 976	596	528	59	2 270

Fast Reeve Crane Blocks 6 sheave

Technical data

Код товара	WLL ton	Model	Rope Ø mm	Sheave dia. mm	Hooksize	B mm	L mm	O mm	T mm	TA mm	TB mm	TLmm mm	Ø D1 mm	Ø D2 mm	Ø Z mm	Bec kg
6097FRB575286200E	200	FRB 575 .28 .6 .200 .E	28	650 / 575	50	1 661	2 317	188	50	770	602	2 081	650	575	59	2 270
6097FRB670286235E	235	FRB 670 .28 .6 .235 .E	28	760 / 670	50	1 716	2 442	188	50	870	952	2 206	760	670	59	4 160
6097FRB670326235E	235	FRB 670 .32 .6 .235 .E	32	760 / 670	50	1 716	2 442	188	60	870	952	2 206	760	670	66	4 160