

# WINCHES

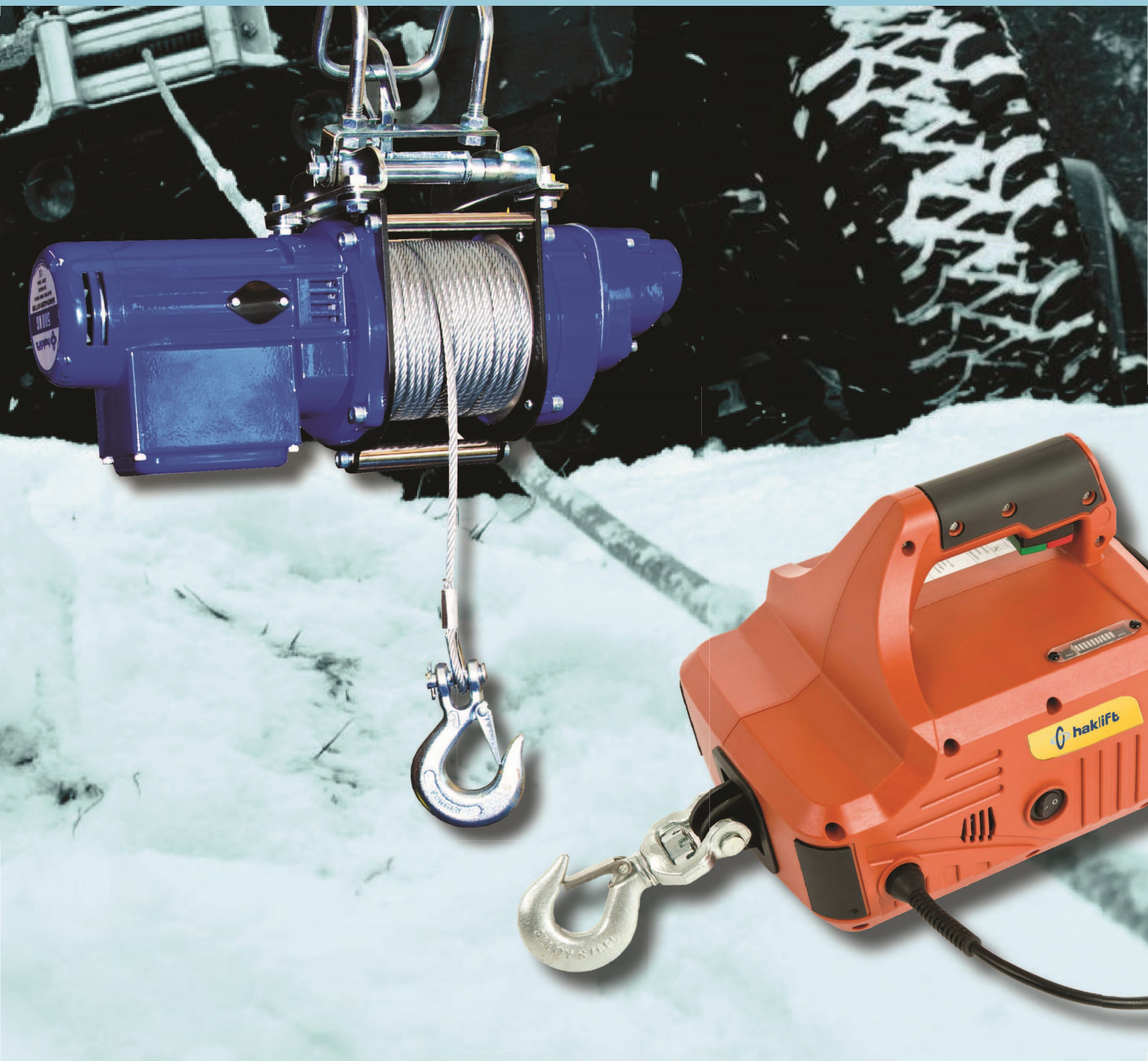

Electric winches 230 V / 380 V »

Direct current winches 12 V / 24 V »

Electric wire winches »

Trailer winches »

Wire rope winches »

## ELECTRIC WINCH MINI 230 V / 50 Hz

- extremely lightweight but powerful winch with attachment hook
- equipped with overload protection
- carbon brush motor

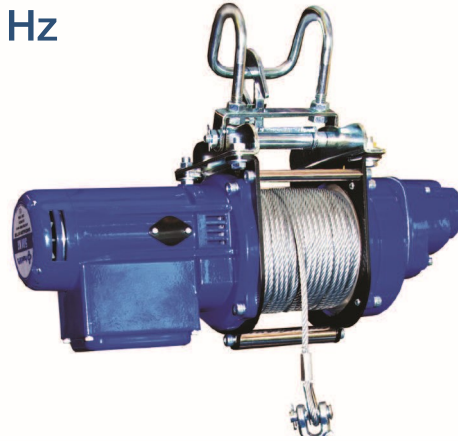

Max. lifting and pulling capacity kg	Oper. voltage V	Steel wire diameter (mm) x length (m)	Motor kW	Speed m/min	Remote control cable m	Power cable m	ED%	Dimensions w x d x h mm	Weight kg	Product code
500	230	6 x 30	1,30	7	2	0,5	40	500x250x330	19	VAVIN500MINI

## ELECTRIC WINCHES 230 V AND 380 V / 50 Hz

- quality and maintenance-free winches for professional use
- equipped with steel wire rope, rotating latch hook and automatic brake
- protection class IP54 / IP51 (VAVINTH300EL and VAVINTH500EL)



Max. lifting and pulling capacity kg	Oper. voltage V	Steel wire diameter (mm) x length (m)	Motor kW	Speed m/min	Remote control cable m	Power cable m	ED%	Dimensions w x d x h mm	Weight kg	Product code
300	230	7 x 30	0,74	15	2	0,5	40	600x210x270	39	VAVINTH300EL
500	380	8 x 45	1,47	21	2	0,5	40	710x310x285	76	VAVINTH500EL
1000	380	10 x 45	2,20	12	2	0,5	40	1120x385x340	145	VAVINTH1000EL
2000	380	12 x 70	3,67	12	10	1,5	40	1290x590x520	392	VAVINTH2000EL

## ELECTRIC WINCH FOR VEHICLES DC 12 V

- permanent magnetic motor
- equipped with steel wire rope and latch hook
- roll guide for wire rope and a separate attachment plate
- to be used with removable cable remote control
- wire free pull function

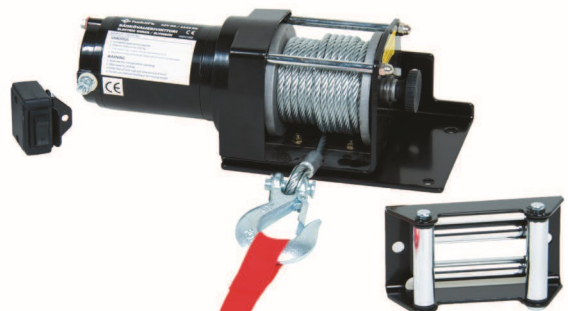

Max. pulling capacity kg	Oper. voltage V	Steel wire diameter (mm) x length (m)	Motor power kW	Pulling speed 0 kg - max m/min	Dimensions W x D x H mm	Remote control cable length m	Weight kg	Product code
1133	12	4,8 x 12,0	0,75	3,2-1,0	283 x 99 x 105	2,8	6,5	VIATV1133

## ELECTRIC WIRE HOIST FOR LIFTING AND PULLING 230 V / 50 Hz



Packed in a display box

- lightweight and easy-to-use electric wire hoist for lifting and pulling
- two models 250 kg and 450 kg
- remote control
- equipped with swivel hook and overload detector

WLL	Operating voltage	Motor	Wire length	Weight	Product code
kg	V	kW	m	kg	
250	230	1,2	8,0	7,0	VANOS250
450	230	1,2	4,6	7,0	VANOS450

## BATTERY OPERATED ELECTRIC WIRE HOIST FOR LIFTING AND PULLING 24 V



Packed in a display box

- lightweight and easy-to-use electric wire hoist for lifting and pulling
- stepless power control
- 2 powerful 24 V NiMH batteries and AC power charger
- equipped with swivel hook and overload detector

WLL	Operating voltage	Motor	Battery	Wire length	Weight	Product code
kg	V	kW	mAh	m	kg	
450	24	0,75	2500	4,6	9,7	VANOS450A

## TRAILER WINCHES



VINT800H  
Packed in a display box



VINT600AT



VINT900AT

- high quality pulling winches for boat and car trailers
- 800 kg winch with two traction gears and mechanical lever brake
- 600 kg and 825 kg painted steel winches with encased automatic brake

Material	Max. pulling capacity	Strap width	Strap length	Weight	Product code
	kg	mm	m	kg	
Steel, painted	600	50	8,0	4,4	VINT600AT
Steel, painted	825	50	8,0	8,0	VINT900AT
Steel, galvanized	800	50	8,0	4,9	VINT800H

## SPARE STRAP TO WINCHES



- equipped with hook
- strap material polyester

Strap length	Strap width	Product code
m	mm	
8,0	50	VV20008

## WINCHES FOR LIFTING AND PULLING



High quality Tiger winch is suitable for both lifting and pulling. Product equipped with wire rope can be used for lifting and pulling and product with strap only for pulling. The winch is equipped with an automatic brake function which ensures that there is no risk of load falling or sliding. Brake system and components are encased and protected from dust and rain. Operating temperature -20 °C - (+)80 °C. Straps and wire ropes are also available separately as spare parts.

Also a stainless model with OCP-coating available.



### WINCHES (Wire rope or strap to be ordered separately)

Lifting capacity	Pulling capacity	Handle length	Gear ratio	Max. wire length	Max. strap length	Drum diameter	Weight	Product code	Product code
t	t	mm		m	m	mm	kg	Painted	Stainless
0,185	0,37	160	4,1:1	36	9,1	40	3,0	VINTT360	VINTT360R
0,275	0,55	210	4,1:1	23	8,5	50	3,5	VINTT550	VINTT550R
0,410	0,82	320	5:1	24	14,1	70	8,0	VINTT800	VINTT800R
0,600	1,20	320	10:1	18	10,6	82	10,5	VINTT1180	VINTT1180R

### WIRE ROPES WITH LATCH HOOK (for lifting and pulling)

For winch	Length m	Diameter mm	Breaking strength	Product code
VINTT360	30	4,0	1270	VINTT360VA430
VINTT550	20	5,0	2000	VINTT550VA520
VINTT800	22	6,0	3000	VINTT800VA622
VINTT1180	16	8,0	4500	VINTT1180VA816

### STRAPS WITH LATCH HOOK (only for pulling)

For winch	Length m	Diameter mm	Breaking strength	Product code
VINTT360	6	48	2068	VINTT48NA6
VINTT550	6	48	2068	VINTT48NA6
VINTT800	9	54	2864	VINTT54NA9
VINTT1180	9	60	4136	VINTT60NA9

## STEEL WIRE ROPE WINCHES

- high class winches for professional use
- suitable for pulling and lifting
- two models, one with handle on the side of the winch and other with handle on top
- equipped with automatic friction brake that operates in both directions
- can be mounted in various ways, for example on the floor or wall
- delivered without wire (must be ordered separately)



Model	Max. load pulling kg	Max. load lifting kg	Max. wire diameter mm	Max. wire length on drum m	Weight without wire kg	Product code
Side handle	150	75	4	22	5,5	VAVIN150
Side handle	300	150	5	40	16,9	VAVIN250
Side handle	500	250	6,8	25	18,8	VAVIN500
Side handle	1000	500	9	25	38,0	VAVIN1000
Side handle	2000	1000	13	30	64,0	VAVIN2000
Top handle	250	125	5	20	10,0	VAVIN250Y
Top handle	500	250	6,8	25	17,0	VAVIN500Y
Top handle	1000	500	9	30	35,0	VAVIN1000Y

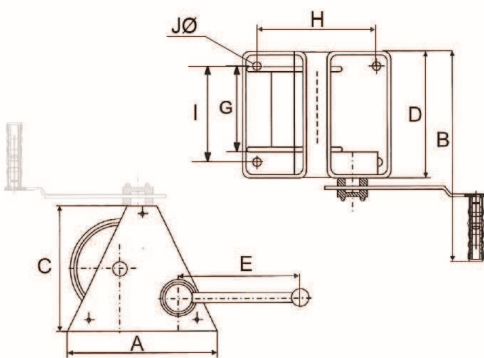

### MEASUREMENTS

Product code	A mm	B mm	C mm	D mm	E mm	G mm	H mm	I mm	JØ mm
VAVIN150	180	325	150	150	350	102	152	112.5	8.5
VAVIN250	240	385	200	200	250	122	196	143	12
VAVIN500	240	385	200	200	250	122	200	145	12
VAVIN1000	412	485	300	300	350	195	367	235	17
VAVIN2000	500	585	325	350	350	285	436	326	20
VAVIN250Y	150	-	150+170	200	240	128	136/100	114	10.5
VAVIN500Y	180	-	180+180	260	240	182	183/130	141	12
VAVIN1000Y	300	-	300+190	300	340	198	247	186	17

## WIRE ROPES FOR WINCHES, WITH SWIVEL LATCH HOOK



Suits for winch kg	Length m	Wire diameter mm	Product code
150/250/300	12	4	VAVIN250VA412
500	14	6	VAVIN500VA614
1000	30	10	VAVIN1000VA1030
2000	13	13	VAVIN2000VA1330

## SPECIAL WINCHES



Tiger winches are manufactured with over 50 years of experience and with high standards for different industries. Products are durable, reliable, safe to use and they meet the industry standards. All winches can be used for lifting purposes.

Here we are introducing few winch models that are available. Contact our sales and we will find a solution for your needs.



### Entertainment 909 kg / 12 m

Available with one or two reels and with or without handle (two reel model in the picture). **Can be used for lifting.**

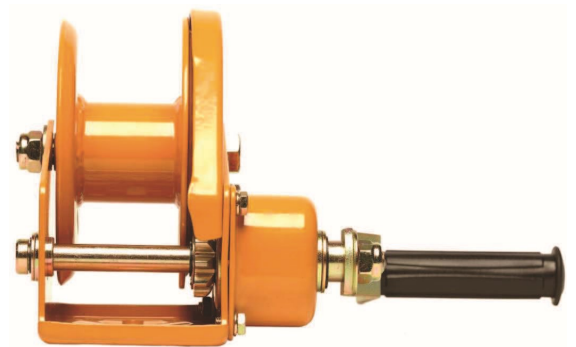

### Silent model 360 / 550 / 800 / 1180 kg

Equipped with patented automatic braking system which guarantees a silent use. Suitable for using in schools, hospitals and theaters. **Can be used for lifting.**



### Ceiling mountable 2270 kg / 11 m

With shared reel which makes reeling possible from opposite directions with two wires. Equipped with brake which keeps the load in place. The brake and gears are protected from dust and rain. **Can be used for lifting.**

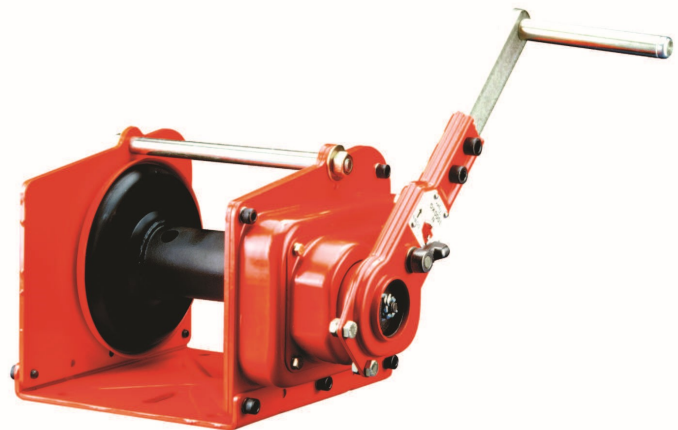

### 1000 kg / 25 m

Equipped with automatic brake which keeps the load in place. The brake and gears are protected from dust and rain. **Can be used for lifting.**